

General Specifications

EXA ISC

ISC40□J Inductive Conductivity Sensors ISC40F□J Holders and Adapters

GS 12D06B01-01E

The ISC40□J sensors are designed for use with the ISC202G/ISC200S 2-wire transmitters and the ISC402G 4-wire converter. This combination exceeds all expectations for conductivity measurement in terms of reliability, accuracy, rangeability and price performance.

The accuracy is 0.5% of reading plus 0.5 $\mu\text{S}/\text{cm}$ for any conductivity value: whether measured in rinse water or in concentrated acids. The materials of construction guarantee a long life under harsh industrial conditions:

The erosion/abrasion resistant PEEK (Poly Ether Ether Ketone), which also features excellent chemical resistance in all solutions except Fluoric Acid or Oxidizing Concentrated Acids.

The PEEK sensor is provided with a rugged Stainless Steel mounting thread/nut/ gasket combination for ultimate flexibility in installation using bulk head installation technique. There is also a wide range of holders and options available for reliable in-line or off-line installation with double O-ring seals for long service life of the sensor.

The ISC40□J have a large bore for optimal resistance to fouling processes and when properly installed, the flow will keep the sensor clean, to help avoid measuring errors.



FEATURES

- Inductive Conductivity technique for elimination of fouling and polarization errors.
- Wide bore sensors for long term stability.
- Installation flexibility due to wide range of holders and due to the use of universal bulkhead construction.
- Wide rangeability in terms of Conductivity (1 $\mu\text{S}/\text{cm}$ to 1999 mS/cm) and temperature (-20 to 130°C).

APPLICATIONS

- All applications where severe electrode fouling prevents the use of contacting electrodes.
- All ranges except (ultra) pure water applications.
- All slurry applications where conventional systems suffer from plugging or erosion.
- All applications where the 6 decade rangeability is necessary for accurate process control.

SYSTEM CONFIGURATION

Refer to GS 12D6D1-E for the ISC402G, GS 12D06A03-01E for the ISC202G and GS 12D6A2-E for the ISC200S.

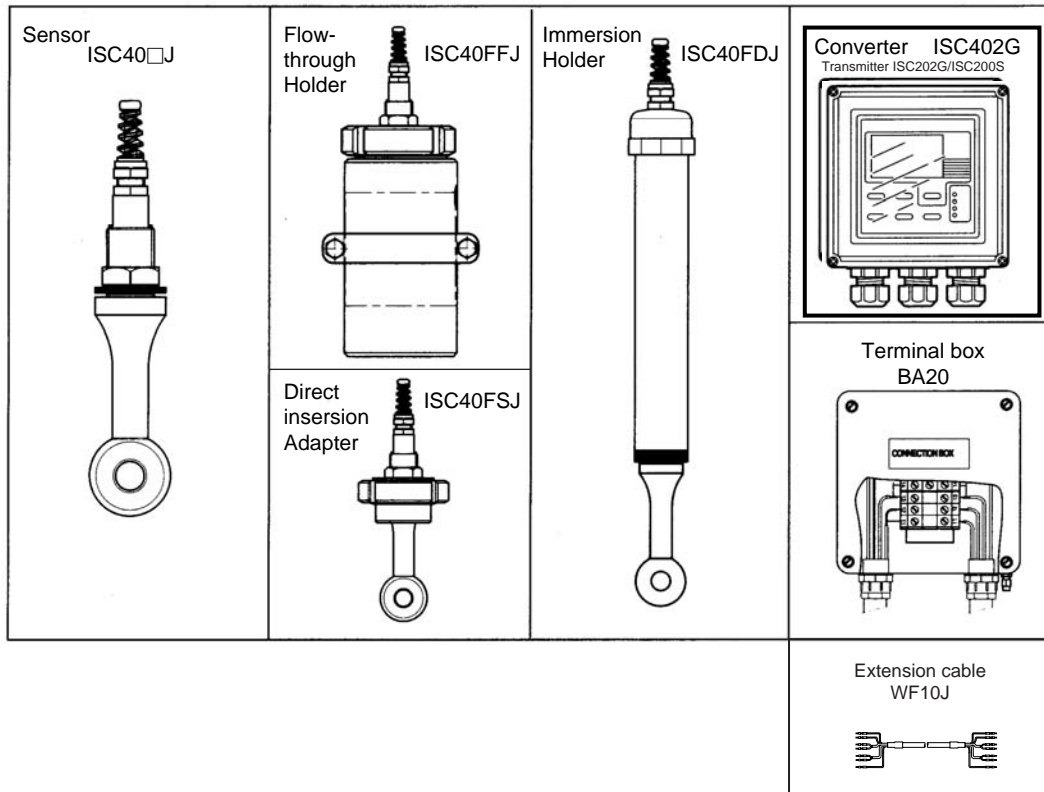

Fig01.eps

GENERAL SPECIFICATION

1. ISC40□J Inductive Conductivity Sensor

Compatibility :

ISC40□J is compatible with ISC202G/ISC200S Inductive Conductivity Transmitter and ISC402G Converter.

Measuring range :

1 μS/cm to 1999 ms/cm

Output span :

Minimum 100 μS/cm
Maximum 1999 mS/cm

Process temperature :

-10 to 130°C for continuous exposure. Suitable for steam-sterilisable applications.

Process pressure :

Dependent on installation; but <2 MPa (300 psi).

Process flow : Maximum 5 m/s.

Wetted materials :

Sensor : PEEK(Poly Ether Ether Ketone).
O-ring : Viton® or ethylene propylene copolymer rubber.
Adapter(optional) : SUS316 Stainless steel or PVC or PVDF.

Now-wetted materials:

Sensor thread : SUS304 Stainless steel.
Retaining nut : SUS304 Stainless steel.
Cable : Weatherproof vinyl.

Process connection :

With retaining nut on G3/4 thread of sensor top (refer to section Drawings and Dimensions) for bulkhead mounting; optional process adapters or process fittings.

Process adapters :

JIS 10K 50 RF flange adapter (Material: SUS316)
JIS 10K 50 FF flange adapter (Material: PVC or PVDF)
DIN PN16 DN50 flange adapter ANSI Class 150 2 flange adapter R2 screw-in adapter

Cable length : 5 m, 10 m, 15 m, 20 m

The length into extension cable is inside of 50 m

Dimensions : Refer to section Drawings and Dimensions.

Weight : Sensor: approximately 0.6 kg.

(Note) Do not submerge the sensor itself in process water, as the seams between the mold and the metal of the sensor are not waterproof. Since a temperature sensor is imbedded in the PEEK molded sensor, its response speed is not fast. Install another temperature sensor if necessary.

2. ISC40FDJ Immersion Holder

Process temperature : Maximum 80°C.

Process pressure : Maximum 0.2 MPa at 20°C. Maximum 0.1 MPa at 80°C.

Wetted materials:

Holder : C-PVC or SUS316
O-ring : Viton® or ethylene propylene copolymer rubber.
Flange (Optional) : PP or SUS316

Process connection :

Fixing flange (Optional) : DIN PN10 DN50 (ANSI 2 inch 150 lbs. with bolt holes) : Material PP
JIS 10K 50 RF : Material SUS316 JIS 2-inch pipe
Mounting set (Optional) : Galvanized steel.

3. ISC40FFJ Flow Holder

Process temperature:

ISC40FFJ-SA, -SJ : Maximum 150°C.
ISC40FFJ-PA, -PJ : Maximum 100°C.
ISC40FFJ-FA, -FJ : Maximum 130°C.

Process pressure:

ISC40FFJ-SA, -SJ : Maximum 1.0 MPa at 150°C.
ISC40FFJ-PA, -PJ : Maximum 0.6 MPa at 20°C.

Maximum 0.1 MPa at 100°C.
ISC40FFJ-FA, -FJ : Maximum 1.0 MPa at 20°C.
Maximum 0.1 MPa at 130°C.

Wetted materials:

ISC40FFJ-S□ : SUS316
ISC40FFJ-P□ : Polypropylene
ISC40FFJ-F□ : PVDF
O-ring : Viton® or ethylene propylene copolymer rubber.

Non-wetted materials:

Nut : SUS304
Mounting set (Optional) : SUS304
Flange adapters (Optional) : SUS304

Process connection :

1/2NPT or Rc1/2
DIN PN10 DN25 flange adapters (Optional)
JIS 10K 25 RF flange adapters (Optional)

4. ISC40FSJ Direct Insertion Subassembly

Process temperature:

ISC40FSJ-STWJ : Maximum 110°C.
ISC40FSJ-SCWJ, -SCSJ : Maximum 150°C.
ISC40FSJ-PCSJ : Maximum 100°C.
ISC40FSJ-FCSJ : Maximum 130°C.

Process pressure:

ISC40FSJ-STWJ : Maximum 1.0 MPa at 110°C.
ISC40FSJ-SCWJ, -SCSJ : Maximum 1.0 MPa at 150°C.
ISC40FSJ-PCSJ : Maximum 0.6 MPa at 20°C.
Maximum 0.1 MPa at 100°C.
ISC40FSJ-FCSJ : Maximum 1.0 MPa at 20°C.
Maximum 0.1 MPa at 130°C.

Materials:

Wetted materials:

ISC40FSJ-STWJ : SUS316L, silicon rubber.
ISC40FSJ-SCWJ, -SCSJ : SUS316, Viton® or ethylene propylene copolymer rubber.
ISC40FSJ-PCSJ : Polypropylene, Viton® or ethylene propylene copolymer rubber.
ISC40FSJ-FCSJ : PVDF, Viton® or ethylene propylene copolymer rubber.

Non wetted materials:

ISC40FSJ-STWJ : IDF clamp: SUS13.
ISC40FSJ-SCWJ, -SCSJ, -PCSJ, -FCSJ:
Nut: SUS304.

Process connection:

ISC40FSJ-STWJ: IDF 3 inch tri-clamp.
ISC40FSJ-SCWJ: coupling.
ISC40FSJ-SCSJ-PCSJ-FCSJ: R2 screw-in coupling.

Dimensions :

Refer to section Drawings and Dimensions.

5. BA20 Terminal Box

Use when ISC202G/ISC200S transmitter or ISC402G converter is separated from ISC40□J sensor and is set up.

- Ambient temperature: -10 to 50°C
- Construction : IP54 agreement
- Case material : Article of cast metal of aluminum alloy
- Cable inlet : 2 (Pg13.5)
- Case color : Straight gray
- Weight : Approx. 2 kg

6. WF10J Extension Cable

- Number of mind Lines : 6
- Finish outside diameter : 7.7 mm
- Terminal processing : Special terminals
- Material : Weatherproof vinyl.

ITEMS TO BE SPECIFIED

Model and Suffix Codes

1. Inductive Conductivity Detector

Model	Suffix code	Option code	Description
ISC40GJ	-----	-----	General Purpose Inductive Conductivity sensor
ISC40SJ	-----	-----	Intrinsic safe Inductive Conductivity sensor
Construction	-GG	-----	Standard type
Temperature sensor	-T1	-----	Pt1000 *1
	-T3	-----	Thermistor
Cable length	-05	-----	5 m
	-10	-----	10 m
	-15	-----	15 m
	-20	-----	20 m
Option Mounting accessories	/SFJ		JIS 10K 50 RF Flange SUS316
	/PFJ		JIS 10K 50 FF Flange PVC
	/FFJ5		JIS 10K 50 FF Flange PVDF
	/SFD		DIN PN16 DN50 Flange SUS316
	/SFA		ANSI Class 150 2 Flange SUS316
	/SSG		R2 screw-in adapter SUS316
	/PSG		R2 screw-in adapter PVC
	/FSJ		R2 screw-in adapter PVDF
/EP		Ethylene propylene rubber O-ring or gasket *2	

*1 Choose thermistor (-T3) only, when connecting with ISC200G or ISC200S.

*2 For use in highly alkaline solutions, be sure to check the process conditions and contact us.

T2.1E.eps

2. Immersion Holder

Model	Suffix code	Option code	Description
ISC40FDJ	-----	-----	Immersion holder
Material	-V	-----	Immersion probe PVC-C
	-S	-----	Immersion probe SUS316
Pipe length	-10	-----	1.0 m
	-15	-----	1.5 m
	-20	-----	2.0 m
Option Mounting accessories	/FA		DIN PN10 DN50 Flange PP (Can be selected for -V) (ANSI Class 150 2 with Bolt-holes)
	/FBJ		JIS 10K 50 RF Flange SUS316
	/MS1		Mounting hardware for immersion type : 1 set
	/MS2		Mounting hardware for immersion type : 2 set
	/EP		Ethylene propylene rubber *

* For use in highly alkaline solutions, be sure to check the process conditions and contact us.

T2.3E.eps

3. Flow-through Holder

Model	Suffix code	Option code	Description
ISC40FFJ	-----	-----	Flow-through holder
Material	-PJ	-----	Rc1/2 Polypropylene (PP)
	-PA	-----	1/2NPT female Polypropylene (PP)
	-SJ	-----	Rc1/2 SUS316
	-SA	-----	1/2NPT female SUS316
	-FJ	-----	Rc1/2 PVDF
	-FA	-----	1/2NPT female PVDF
Option Mounting Accessories	/MS		Wall/pipe mounting hardware for SUS holder
	/MP		Wall/pipe mounting hardware for PP or PVDF holder
	/FSJ2		JIS 10K 25 RF Flange SUS316 (for -SJ) *1
	/FS2		DIN PN10 DN25 Flange SUS316 (for -SA)*1
	/FPJ2		JIS 10K 25 RF Flange PP (for -PJ)*1
	/FP2		DIN PN10 DN25 Flange PP (for -PA)*1
	/FFJ2		JIS 10K 25 RF Flange PVDF (for -FJ)*1
	/FF2		DIN PN10 DN25 Flange PVDF (for -FA)*1
/EP		Ethylene propylene rubber *2	
/POL		Polished surface *3	

*1 All flanges are adjustable. Each material in the above description represents the one of wetted part of the adjustable flange which itself is made of SUS304.

*2 For use in highly alkaline solutions, be sure to check the process conditions and contact us.

*3 Option in case of SUS316 material. T2.4E.eps

4. Direct Insertion Adapter

Model	Suffix code	Option code	Description
ISC40FSJ	-----	-----	Direct insertion adapter
Process connection	-PCSJ	-----	R2 screw-in coupling PP
	-SCWJ	-----	Coupling welded SUS316
	-SCSJ	-----	R2 screw-in coupling SUS316
	-STWJ	-----	IDF 3 inch clamp SUS316L
	-FCSJ	-----	R2 screw-in coupling PVDF
Option		/EP	Ethylene propylene rubber *

T2.5E.eps

* For use in highly alkaline solutions, be sure to check the process conditions and contact us.

5. Terminal Box

Model	Suffix code	Option code	Description
BA20	-----	-----	Terminal box

6. Extension Cable

Model	Suffix code	Option code	Description
WF10J	-----	-----	Extension cable
Cable end	-F	-----	End finished
Cable length	-05	-----	5 m
	-10	-----	10 m
	-20	-----	20 m
	-30	-----	30 m
	-40	-----	40 m

T2.7E.eps

(Note) The maximum extension cable length is 50 m including sensor cable length.

DIMENSIONS

1. ISC40□J Inductive Conductivity Detector

Unit : mm

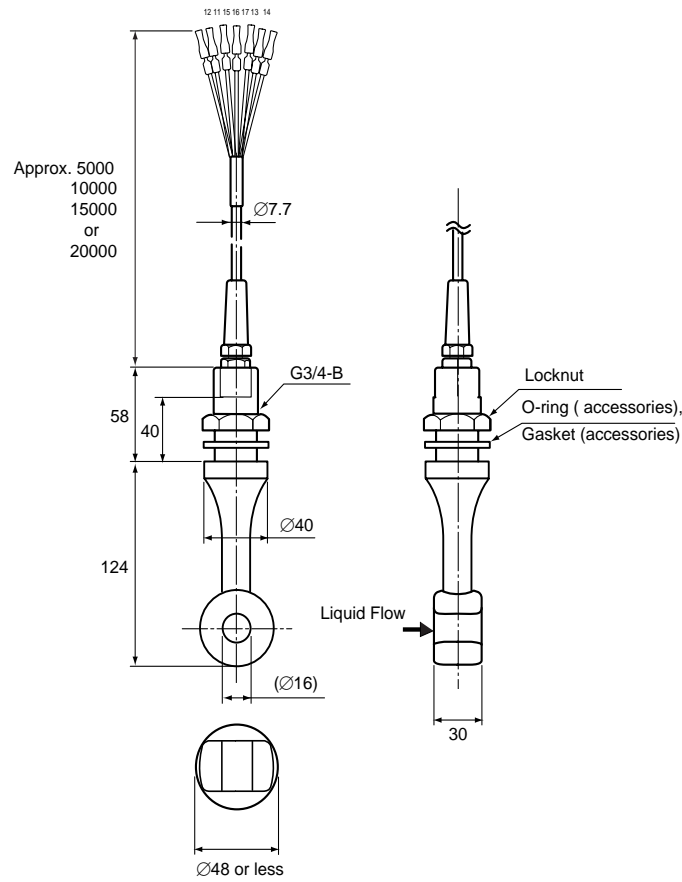

Process Adapters

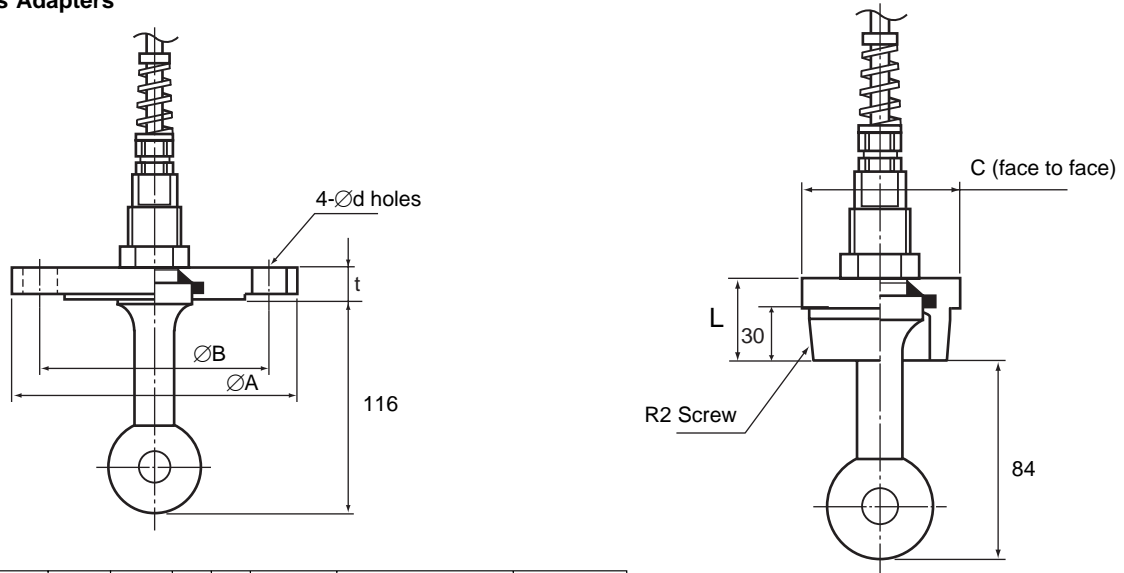

Option Code	A	B	d	t	Material	Flange Rating	Weight (kg)
/SFJ	155	120	19	16	SUS316	JIS 10K 50 RF	Approx. 1.9
/PFJ	155	120	19	20	PVC	JIS 10K 50 FF	Approx. 0.5
/FFJ5	155	120	19	20	PVDF	JIS 10K 50 FF	Approx. 0.5
/SFD	165	125	18	18	SUS316	DIN PN16 DN50	Approx. 2.7
/SFA	152.4	120.6	19	19	SUS316	ANSI Class 150 2	Approx. 3.0

Flange adapter

Option Code	C	L	Material	Weight (kg)
/SSG	60	46	SUS316	Approx. 0.4
/PSG	70	48	PVC	Approx. 0.15
/FSJ	70	48	PVDF	Approx. 0.15

Thread adapter

2. ISC40FDJ Immersion Holder

Unit : mm

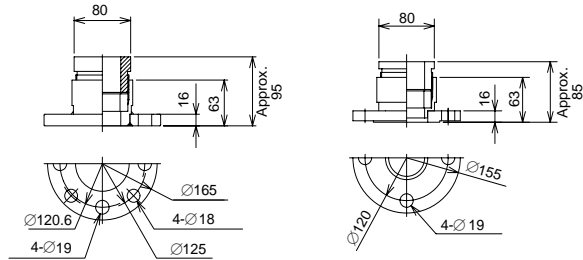
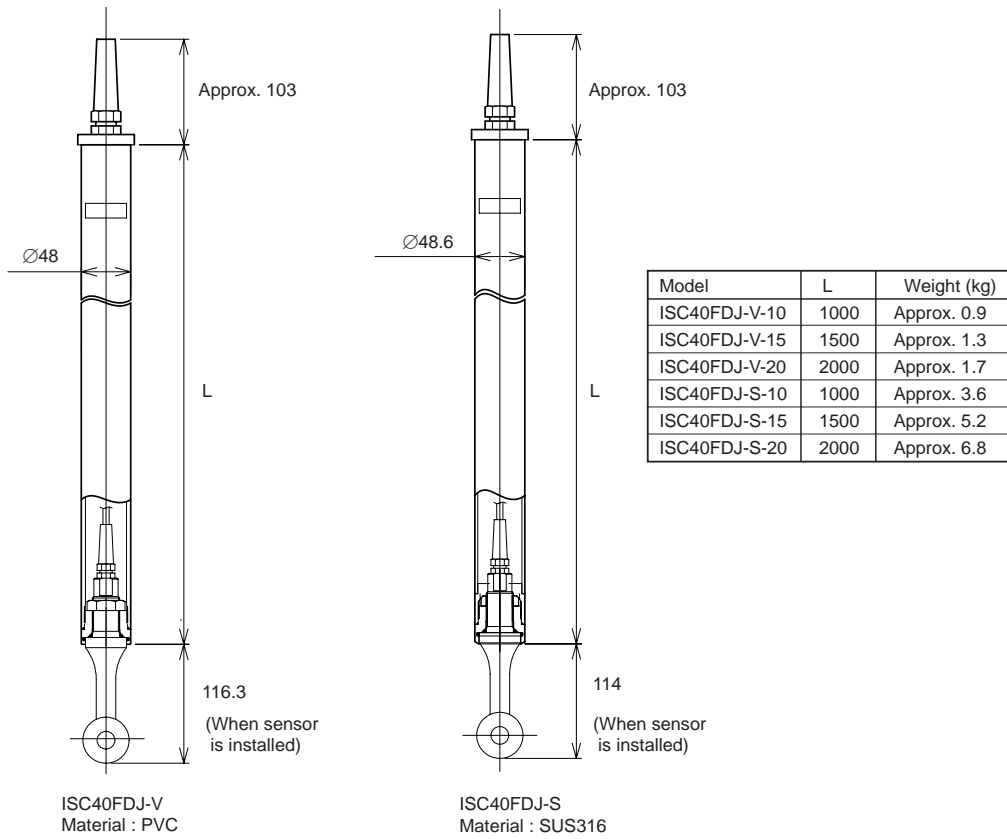

Option Code : /FA

DIN PN10 DN50 (Note)
(ANSI Class 150 2)
Material : PP

Option Code : /FBJ

JIS 10K 50 RF (Note)
Material : SUS316

(Note) Only mating dimensions are according to flange standards.

Flange (Option)

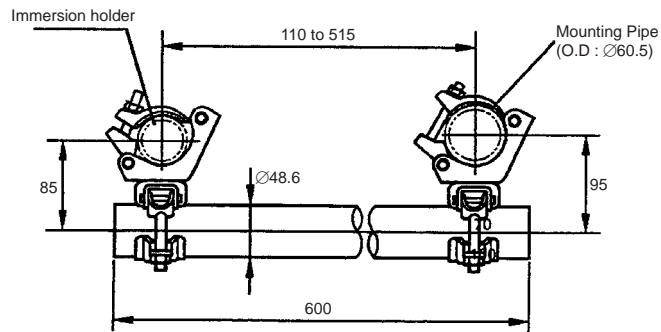

Immersion holder mounting hardware : /MS1 or /MS2 option

3. ISC40FFJ Flow Holder

Unit : mm

Material : SUS (ISC40FFJ-SJ, -SA)

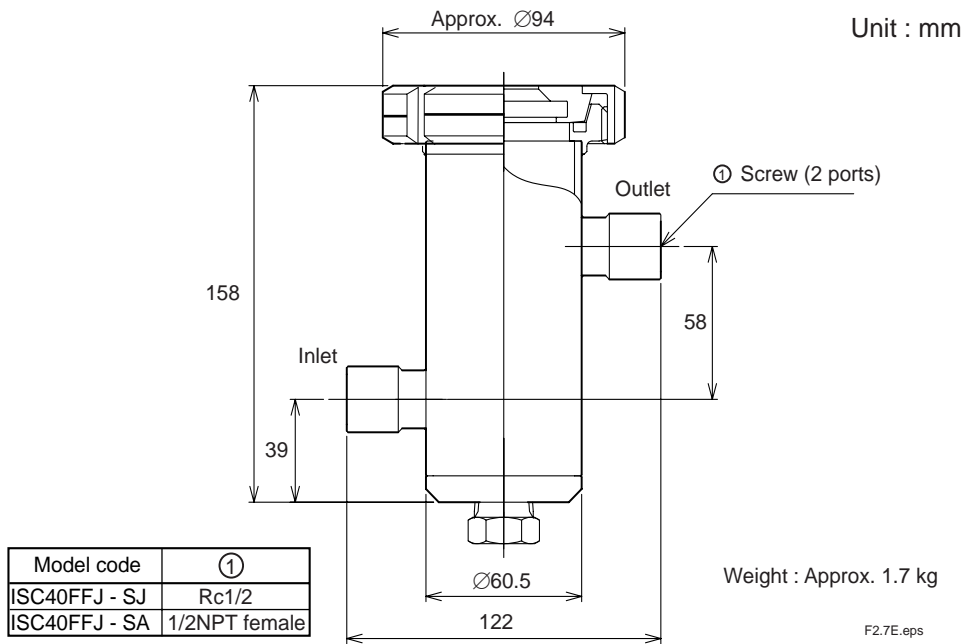

Mounting hardware when /MS option specified

Weight : Approx. 0.5 kg

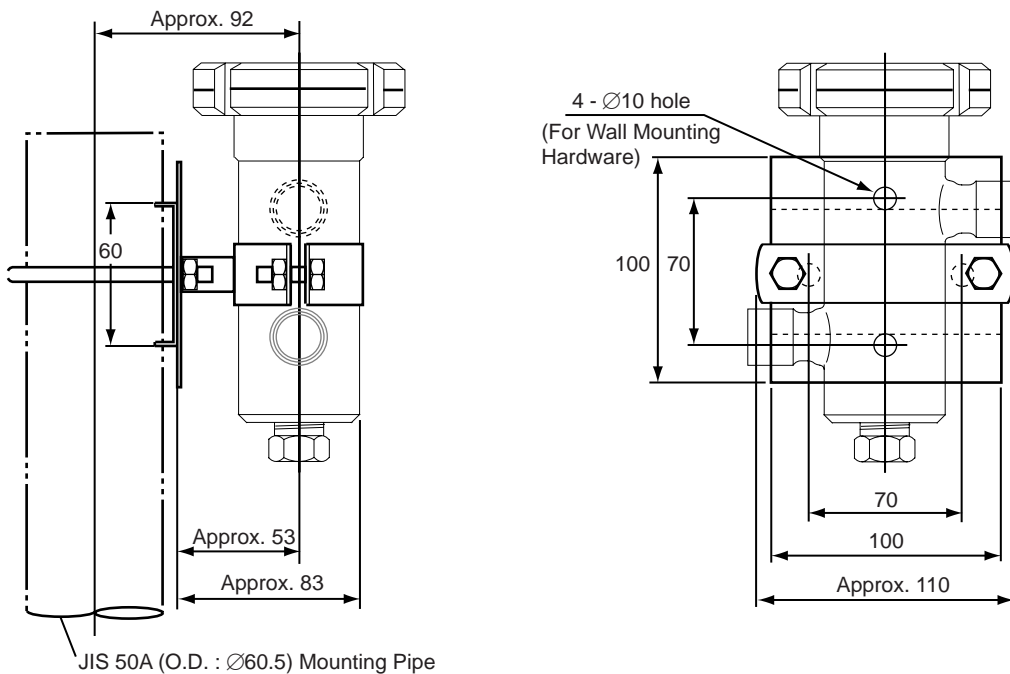

Material : SUS, with Flange (ISC40FFJ-SJ/FSJ2, ISC40FFJ-SA/FS2)

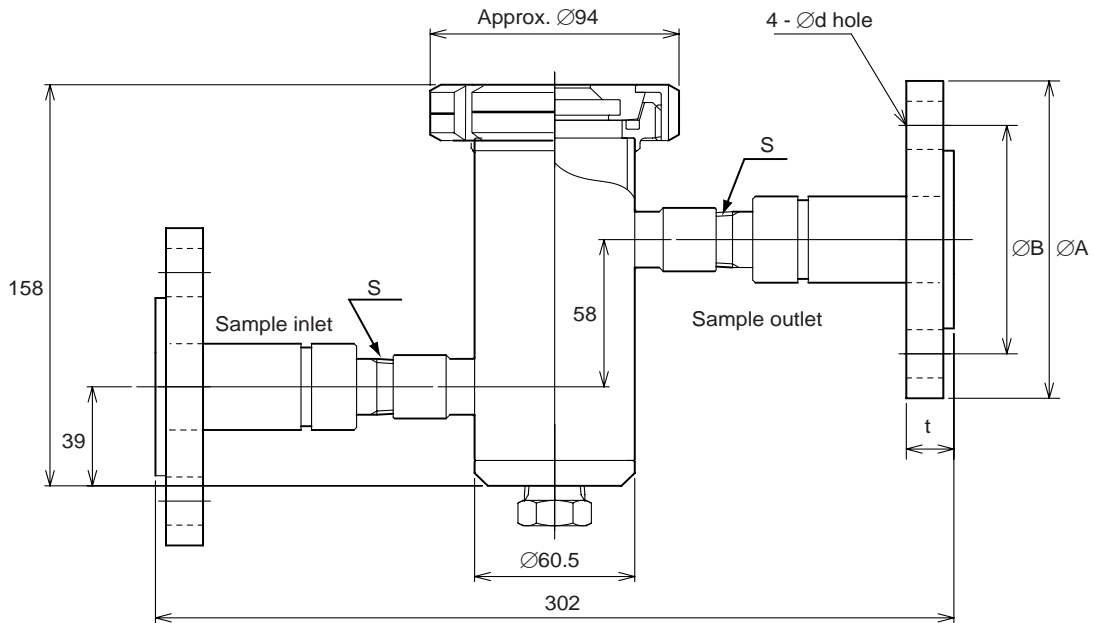

Model code	Flange standard	A	B	d	t	S	Weight (kg)
ISC40FFJ - SJ / FSJ2	JIS 10K 25 RF	125	90	19	Approx. 18	R 1/2	Approx. 4.7
ISC40FFJ - SA / FS2	DIN PN10 DN25	115	85	14	Approx. 19	1/2 NPT	Approx. 4.7

F2.9E.eps

Material : PP or PVDF (ISC40FFJ-PJ, -PA, -FJ, -FA)

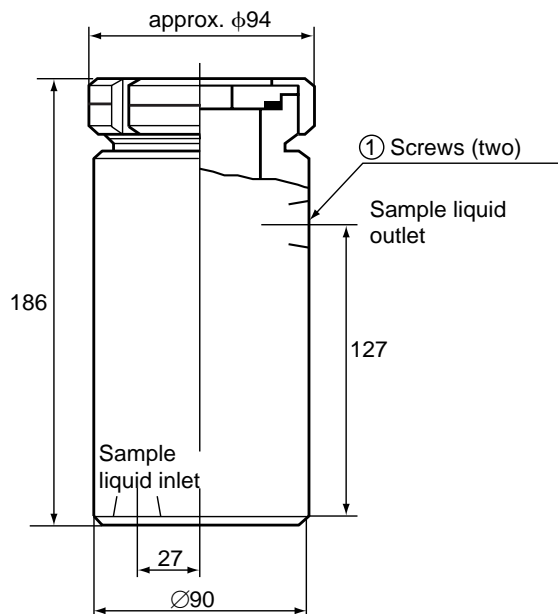

Model code	①	Weight (kg)
ISC40FFJ - PJ	Rc 1/2	Approx. 0.9
ISC40FFJ - FJ		Approx. 1.4
ISC40FFJ - PA	1/2 NPT	Approx. 0.9
ISC40FFJ - FA	female	Approx. 1.4

F2.11E.eps

Mounting hardware when /MP option specified

□ Option code : / MP Mounting Bracket Weight : Approx. 0.5 kg

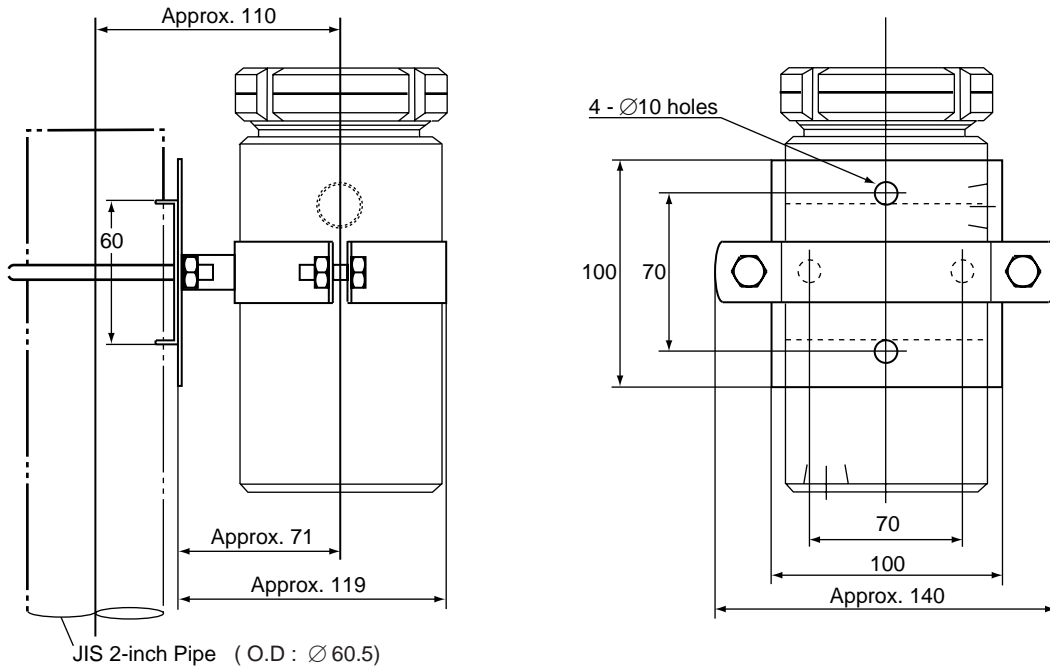

Material : PP or PVDF, with Flange (ISC40FFJ-PJ/FPJ2, ISC40FFJ-PA/FP2, ISC40FFJ-FJ/FFJ2, ISC40FFJ-FA/FF2)

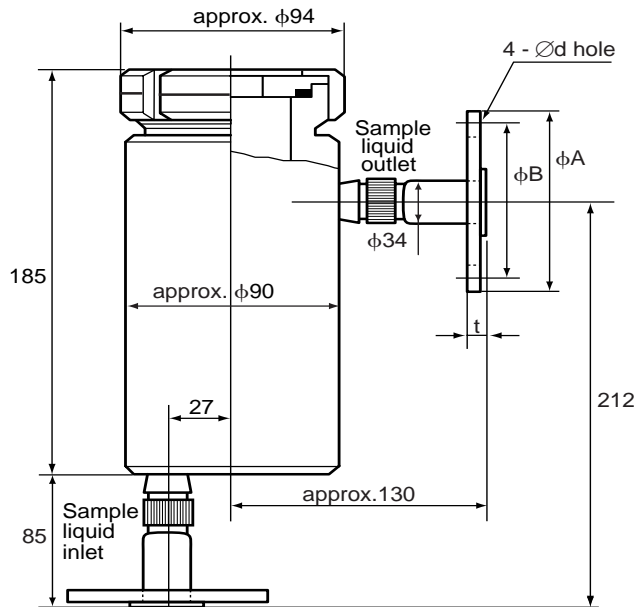

ISC40FFJ - PA, - PJ, -FA, -FJ /FP2, / FPJ2, / FF2, / FFJ2 (with flange)

F2.13E.eps

Model code	Flange standard	A	B	d	t	Weight (kg)
ISC40FFJ - PJ / FPJ2	JIS 10K 25 RF	125	90	19	approx. 20	Approx. 3.2 kg
ISC40FFJ - FJ / FFJ2						Approx. 3.9 kg
ISC40FFJ - PA / FP2	DIN PN10 DN25	115	85	14	approx. 19	Approx. 3.2 kg
ISC40FFJ - FA / FF2						Approx. 3.9 kg

4. ISC40FSJ Direct Insertion Subassembly

Unit : mm

IDF Clamp
ISC40FSJ-STWJ

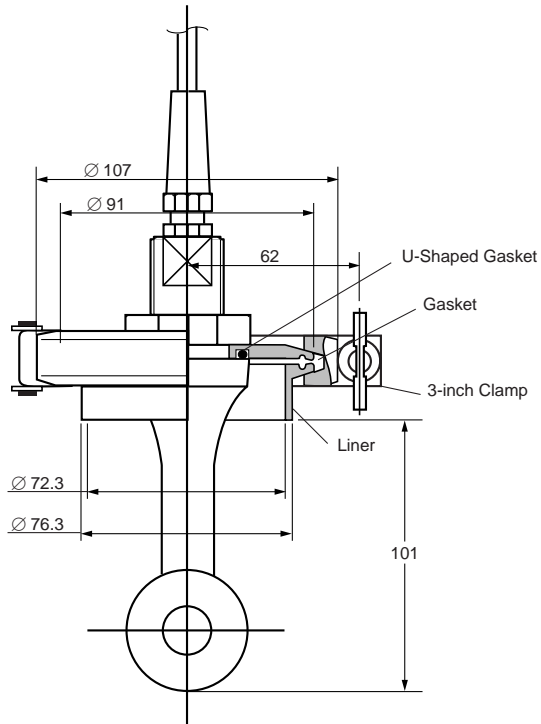

Weight : Approx. 0.8 kg

Coupling welded
ISC40FSJ-SCWJ

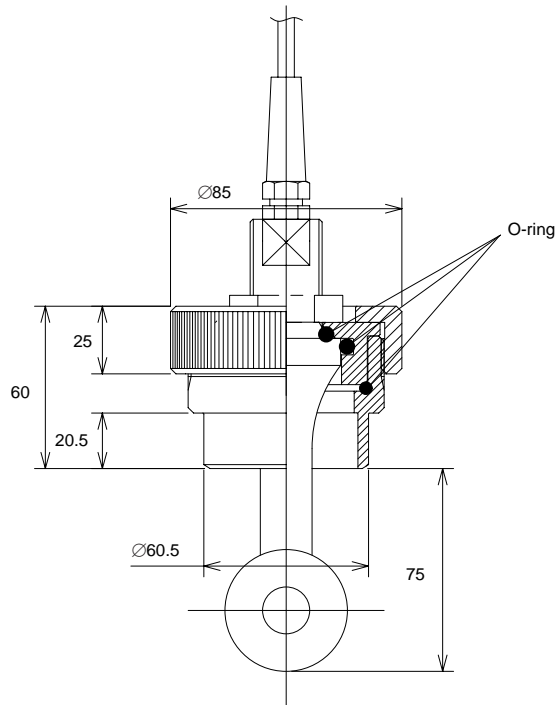

Weight : Approx. 1.2 kg

Screw-in socket
ISC40FSJ-SCSJ, ISC40FSJ-PCSJ, ISC40FSJ-FCSJ

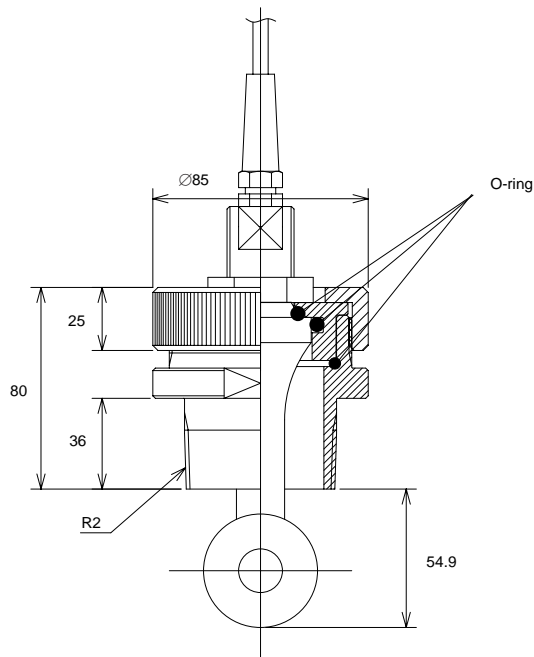

Weight : Approx. 0.7 to 1.4 kg

5. BA20 Terminal Box

Unit : mm

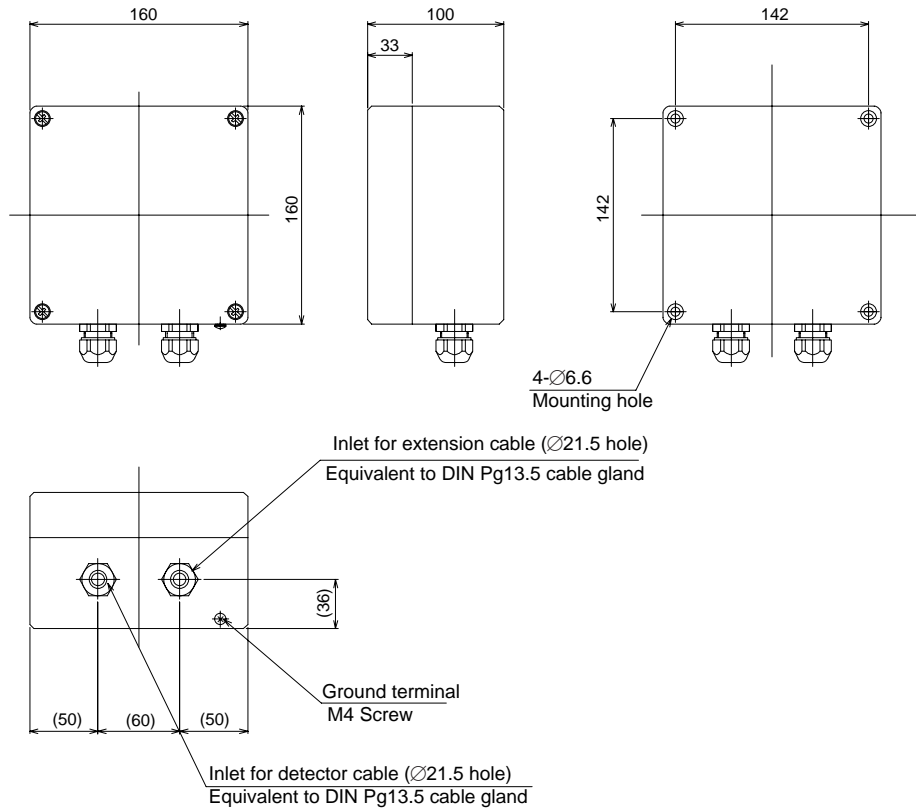

Wiring

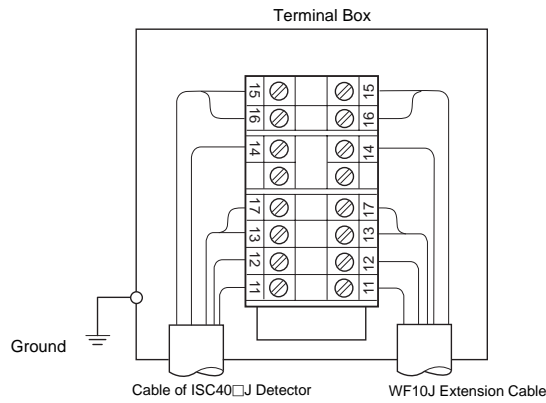

6. WF10J Extension Cable

Unit : mm

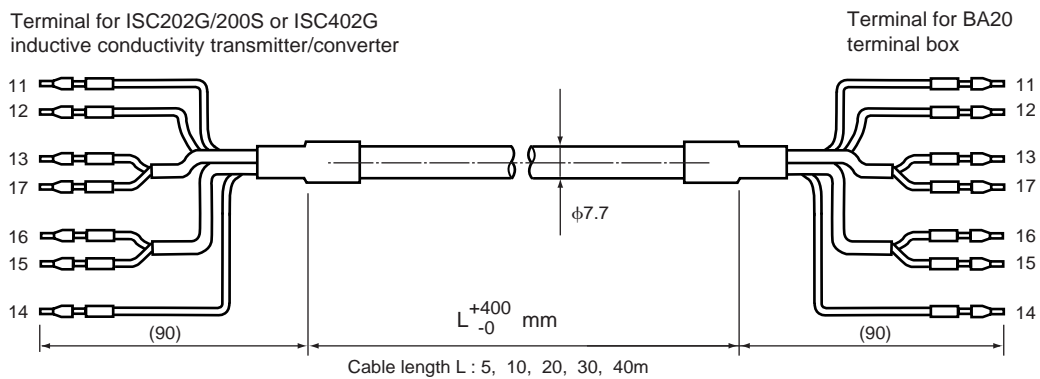

TABLE OF CORROSION-RESISTANT MATERIALS

This chemical resistance table is based on reference data provided by manufacturers and shows the chemical resistance of materials to individual chemical. If a sample contains multiple chemicals, the resistance characteristics may differ from the table specifications. Since sample conditions in an actual application are influenced by various factors, the sensor may not be applicable to some applications. The data should be used for reference only.

Chemical Resistance Table for ISC40															
		Holder Material				Sealing Material			Sensor Body						
		PVDF		SUS316		PP		PVC		FPM	EPDM	PEEK			
Reagent	Temp. concentration	20	60	100	20	60	100	20	60	100	20	60	100	20	100
	Sulfuric acid	10% 50% 98%	◎ ◎ ◎	◎ ◎ ◎	◎ ◎ ◎	◎ ◎ ×	◎ ◎ ×	◎ ◎ ×	◎ ◎ ×	◎ ◎ ×	◎ ◎ ◎	◎ ◎ ×	◎ ◎ ×	◎ ◎ ×	less than 40% 40% or more
Fuming sulfuric acid	(98%)	× × ×	× × ×	× × ×	○ ○ ×	× × ×	× × ×	× × ×	× × ×	× × ×	× × ×	× × ×	× × ×	× × ×	× × ×
Hydrochloric acid	15% 38%	◎ ◎ ◎	◎ ◎ ◎	◎ ◎ ◎	× × ×	× × ×	× × ×	◎ ◎ ×	◎ ◎ ×	◎ ◎ ×	◎ ◎ △	◎ ◎ ×	◎ ◎ ×	◎ ◎ ×	◎ ◎ ×
Nitric acid	30% 50% 98%	◎ ◎ ◎	◎ ◎ ◎	◎ ◎ ◎	◎ ◎ ×	◎ ◎ ×	◎ ◎ ×	◎ × ×	◎ × ×	◎ × ×	◎ ○ △	◎ △ ×	◎ △ ×	◎ △ ×	◎ △ ×
Phosphoric acid	10% 50% 98%	◎ ◎ ◎	◎ ◎ ◎	◎ ◎ ◎	◎ ◎ ×	◎ ◎ ×	◎ ◎ ×	◎ ◎ ×	◎ ◎ ×	◎ ◎ ×	◎ ◎ ×	◎ ◎ ×	◎ ◎ ×	◎ ◎ ×	◎ ◎ ×
Hydrofluoric acid	40% 50%	◎ ◎ ◎	◎ ◎ ◎	◎ ◎ ◎	× × ×	× × ×	× × ×	◎ ○ ×	◎ ○ ×	◎ ○ ×	◎ ◎ ○	◎ ◎ ○	◎ ◎ ○	◎ ◎ ○	◎ ◎ ○
Acetic acid	20% 80%	◎ ◎ ○	◎ ◎ ○	◎ ◎ ○	◎ × ×	◎ × ×	◎ × ×	○ △ ×	○ △ ×	○ △ ×	○ △ ×	○ △ ×	○ △ ×	○ △ ×	○ △ ×
Glacial acetic acid	96%	◎ ○ △	◎ ○ △	◎ ○ △	× × ×	× × ×	× × ×	○ × ×	○ × ×	○ × ×	○ × ×	○ × ×	○ × ×	○ × ×	○ × ×
Formic acid	90%	◎ ◎ ○	◎ ◎ ○	◎ ◎ ○	× × ×	× × ×	× × ×	◎ × ×	◎ × ×	◎ × ×	× × ×	× × ×	× × ×	× × ×	× × ×
Citric acid	10%	◎ ◎ ◎	◎ ◎ ◎	◎ ◎ ◎	◎ ◎ ×	◎ ◎ ×	◎ ◎ ×	◎ ○ ×	◎ ○ ×	◎ ○ ×	◎ ◎ ◎	◎ ◎ ◎	◎ ◎ ◎	◎ ◎ ◎	◎ ◎ ◎
Calcium hydroxide	Saturated	◎ ◎ ◎	◎ ◎ ◎	◎ ◎ ◎	× × ×	× × ×	× × ×	◎ ◎ ○	◎ ◎ ○	◎ ◎ ○	◎ ◎ ◎	◎ ◎ ◎	◎ ◎ ◎	◎ ◎ ◎	◎ ◎ ◎
Potassium hydroxide	25%	◎ ○ ×	◎ ○ ×	◎ ○ ×	◎ ◎ ○	◎ ◎ ○	◎ ◎ ○	◎ ◎ ×	◎ ◎ ×	◎ ◎ ×	× × ×	× × ×	× × ×	× × ×	× × ×
Sodium hydroxide	50%	◎ × ×	◎ × ×	◎ × ×	◎ ◎ ◎	◎ ◎ ◎	◎ ◎ ◎	◎ ◎ ×	◎ ◎ ×	◎ ◎ ×	× × ×	× × ×	× × ×	× × ×	× × ×
Ammonia water	10%	◎ ◎ ◎	◎ ◎ ◎	◎ ◎ ◎	○ × ×	○ × ×	○ × ×	◎ ◎ ×	◎ ◎ ×	◎ ◎ ×	○ × ×	○ × ×	○ × ×	○ × ×	○ × ×
Ammonium chloride	Saturated	◎ ◎ ◎	◎ ◎ ◎	◎ ◎ ◎	◎ × ×	◎ × ×	◎ × ×	◎ ◎ ×	◎ ◎ ×	◎ ◎ ×	◎ ◎ ◎	◎ ◎ ◎	◎ ◎ ◎	◎ ◎ ◎	◎ ◎ ◎
Zinc chloride	Saturated	◎ ◎ ×	◎ ◎ ×	◎ ◎ ×	○ ○ ×	○ ○ ×	○ ○ ×	◎ ◎ ×	◎ ◎ ×	◎ ◎ ×	◎ ◎ ×	◎ ◎ ×	◎ ◎ ×	◎ ◎ ×	◎ ◎ ×
Iron (II) chloride	20%	◎ ◎ ◎	◎ ◎ ◎	◎ ◎ ◎	× × ×	× × ×	× × ×	◎ ◎ ×	◎ ◎ ×	◎ ◎ ×	◎ ◎ ○	◎ ◎ ○	◎ ◎ ○	◎ ◎ ○	◎ ◎ ○
Sodium carbonate	Saturated	◎ ◎ ◎	◎ ◎ ◎	◎ ◎ ◎	◎ ○ ×	◎ ○ ×	◎ ○ ×	◎ ◎ ×	◎ ◎ ×	◎ ◎ ×	◎ ◎ ◎	◎ ◎ ◎	◎ ◎ ◎	◎ ◎ ◎	◎ ◎ ◎
Potassium chloride	30%	◎ ◎ ◎	◎ ◎ ◎	◎ ◎ ◎	◎ ◎ ×	◎ ◎ ×	◎ ◎ ×	◎ ◎ ×	◎ ◎ ×	◎ ◎ ×	◎ ◎ ◎	◎ ◎ ◎	◎ ◎ ◎	◎ ◎ ◎	◎ ◎ ◎
Sodium sulfate	Saturated	◎ ◎ ◎	◎ ◎ ◎	◎ ◎ ◎	◎ ◎ ×	◎ ◎ ×	◎ ◎ ×	◎ ◎ ×	◎ ◎ ×	◎ ◎ ×	◎ ◎ ◎	◎ ◎ ◎	◎ ◎ ◎	◎ ◎ ◎	◎ ◎ ◎
Calcium chloride	Saturated	◎ ◎ ◎	◎ ◎ ◎	◎ ◎ ◎	× × ×	× × ×	× × ×	◎ ◎ ×	◎ ◎ ×	◎ ◎ ×	◎ ◎ ◎	◎ ◎ ◎	◎ ◎ ◎	◎ ◎ ◎	◎ ◎ ◎
Sodium chloride	Saturated	◎ ◎ ◎	◎ ◎ ◎	◎ ◎ ◎	× × ×	× × ×	× × ×	◎ ◎ ×	◎ ◎ ×	◎ ◎ ×	◎ ◎ ×	◎ ◎ ×	◎ ◎ ×	◎ ◎ ×	◎ ◎ ×
Sodium nitrate	Saturated	◎ ◎ ◎	◎ ◎ ◎	◎ ◎ ◎	◎ ◎ ◎	◎ ◎ ◎	◎ ◎ ◎	◎ ◎ ×	◎ ◎ ×	◎ ◎ ×	◎ ◎ ◎	◎ ◎ ◎	◎ ◎ ◎	◎ ◎ ◎	◎ ◎ ◎
Aluminum chloride	Saturated	◎ ○ ×	◎ ○ ×	◎ ○ ×	× × ×	× × ×	× × ×	◎ ◎ ×	◎ ◎ ×	◎ ◎ ×	◎ ◎ ◎	◎ ◎ ◎	◎ ◎ ◎	◎ ◎ ◎	◎ ◎ ◎
Hydrogen peroxide	30%	◎ ◎ ◎	◎ ◎ ◎	◎ ◎ ◎	× × ×	× × ×	× × ×	◎ ○ ×	◎ ○ ×	◎ ○ ×	◎ ○ ×	◎ ○ ×	◎ ○ ×	◎ ○ ×	◎ ○ ×
Sodium hypochlorite (*)	13%	◎ ○ ×	◎ ○ ×	◎ ○ ×	△ × ×	△ × ×	△ × ×	◎ ○ ×	◎ ○ ×	◎ ○ ×	◎ × ×	◎ × ×	◎ × ×	◎ × ×	◎ × ×
Potassium dichromate	Saturated	◎ ◎ ◎	◎ ◎ ◎	◎ ◎ ◎	◎ ◎ ◎	◎ ◎ ◎	◎ ◎ ◎	◎ △ ×	◎ △ ×	◎ △ ×	◎ ◎ ◎	◎ ◎ ◎	◎ ◎ ◎	◎ ◎ ◎	◎ ◎ ◎
Ethanol	100%	◎ ◎ ×	◎ ◎ ×	◎ ◎ ×	○ ○ ×	○ ○ ×	○ ○ ×	◎ ○ ×	◎ ○ ×	◎ ○ ×	◎ ◎ ×	◎ ◎ ×	◎ ◎ ×	◎ ◎ ×	◎ ◎ ×
Cyclohexane	100%	◎ ◎ ×	◎ ◎ ×	◎ ◎ ×	× × ×	× × ×	× × ×	△ × ×	△ × ×	△ × ×	× × ×	× × ×	× × ×	× × ×	× × ×
Toluene	100%	◎ ○ ×	◎ ○ ×	◎ ○ ×	× × ×	× × ×	× × ×	◎ × ×	◎ × ×	◎ × ×	○ × ×	○ × ×	○ × ×	○ × ×	○ × ×
Water	100%	◎ ◎ ◎	◎ ◎ ◎	◎ ◎ ◎	◎ ◎ ◎	◎ ◎ ◎	◎ ◎ ◎	◎ ◎ ×	◎ ◎ ×	◎ ◎ ×	◎ ◎ ×	◎ ◎ ×	◎ ◎ ×	◎ ◎ ×	◎ ◎ ×

- ◎ Very suitable
- Suitable
- △ Slightly unsuitable
- × Unusable

(*) Unusable with any material when this coexists with an acidic solution or oxides.

Inductive Conductivity Sensors and Holders System Inquiry Specifications

Make inquiries by filling in related boxes with checks (✓) and writing in the underlined parts.

1. General Items

Name of your company: _____

Person in charge: _____ Belongs to: _____ (Phone No. _____)

Name of plant: _____

Measuring point: _____

Purpose of use: Indication Record Alarm Control

Power supply to Distributor: _____ V AC

2. Measuring conditions

(1) Liquid temperature: _____ to _____ ,normal _____ [°C]

(2) Liquid pressure: _____ to _____ ,normal _____ [kPa {kgf/cm²G}]

(3) Flow rate: _____ to _____ ,normal _____ [l/min.]

(4) Flow speed: _____ to _____ ,normal _____ [m/s]

(5) Slurry of fouling components: No Yes

(6) Name of measured liquid: _____

(7) Components of measured liquid: _____

(8) Others: _____

3. Installing Location

(1) Ambient temperature: _____

(2) Installing location: Outdoors Indoors _____

(3) Others: _____

4. Specification Requirements

(1) Measuring range: _____

(2) System configuration selection: Sensor Holder Terminal box Extension cable

(3) Detector mounting: Immersion Flow-through Direct insertion

(4) Sensor cable length: 5m 10m 15m 20m

(5) Extension cable length: 5m 10m 20m 30m 40m

(6) Others: _____